

IMPACT Instrument Suite Overview

David Curtis, UC Berkeley Space Sciences Lab,
dwc@ssl.berkeley.edu, (510) 642-5998

IMPACT (In-situ Measurements of Particles and CME Transients) Instrument Overview

- **Boom Suite:**
 - Solar Wind Electron Analyzer (SWEA)
 - Suprathermal Electron Telescope (STE)
 - Magnetometer (MAG)
- **Solar Energetic Particles Package (SEP)**
 - Suprathermal Ion Telescope (SIT)
 - Solar Electron and Proton Telescope (SEPT)
 - Low Energy Telescope (LET)
 - High Energy Telescope (HET)
- **Support:**
 - IMPACT Boom
 - SEP Central
 - Instrument Data Processing Unit (IDPU)

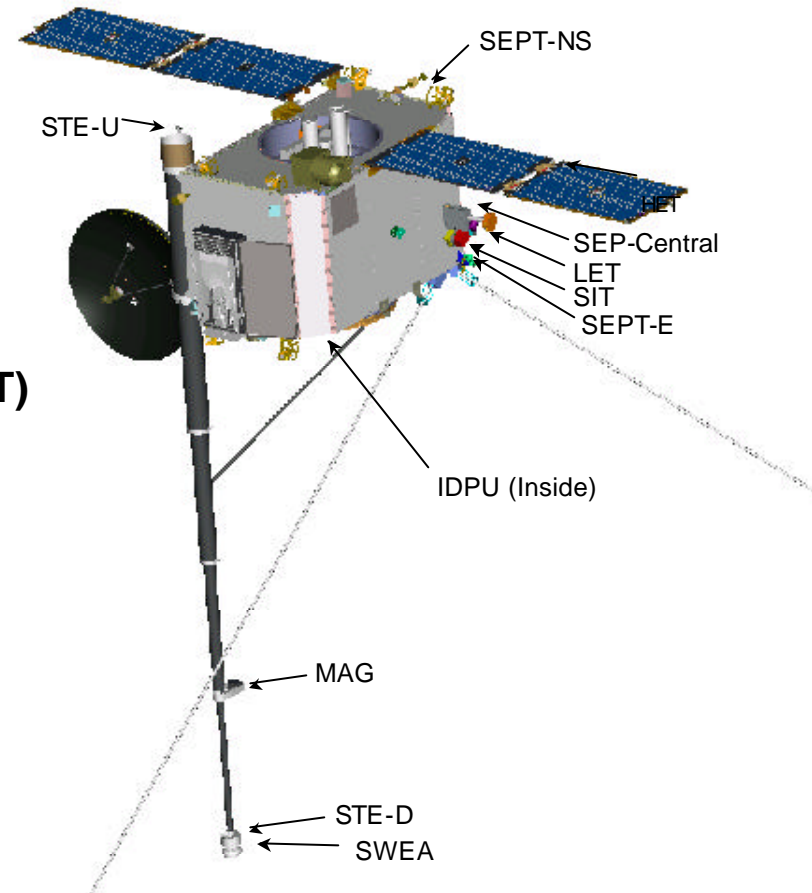

IMPACT Organization Chart

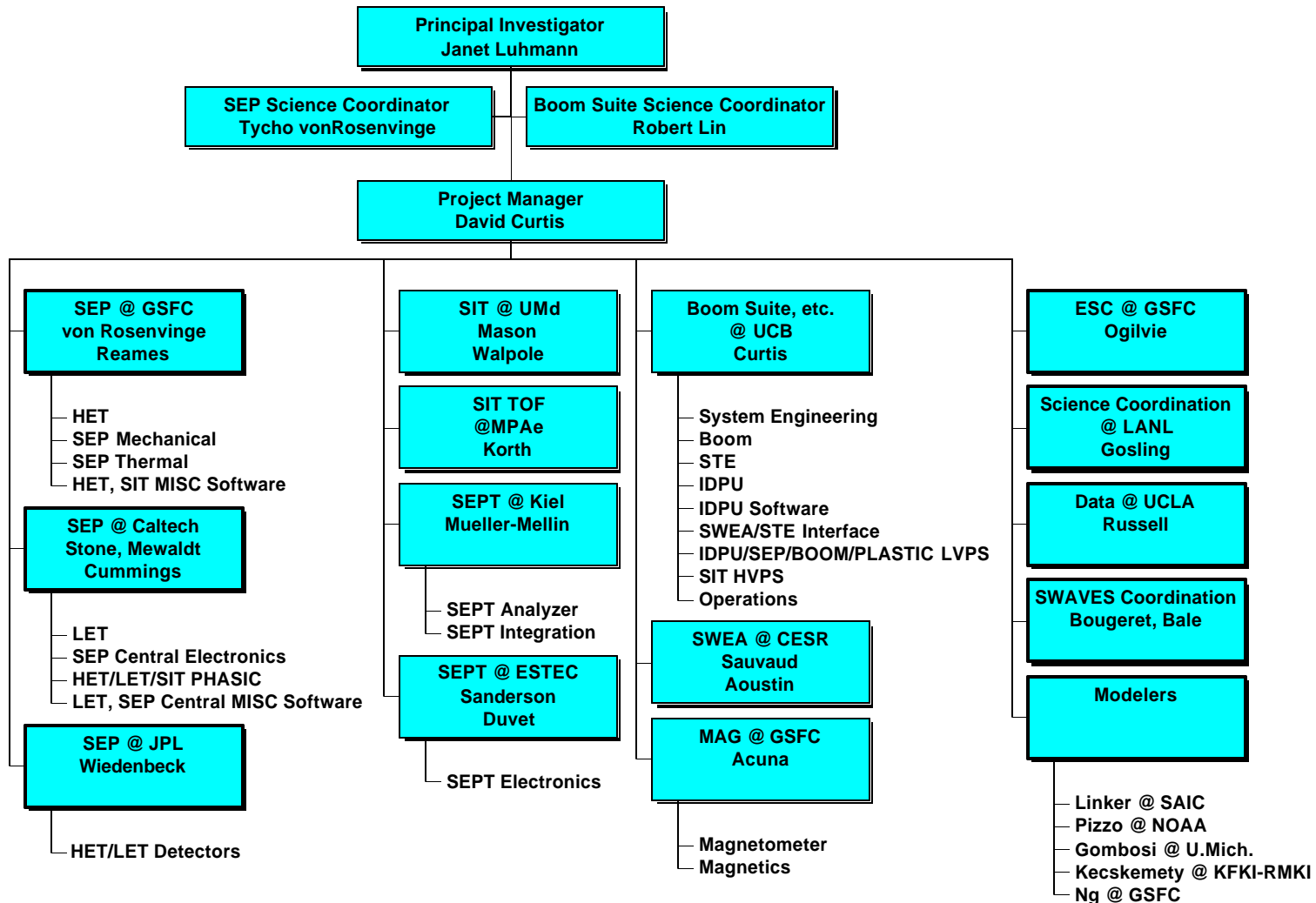

STEREO IMPACT

Observatory Critical Design Review
2003 February 18-21

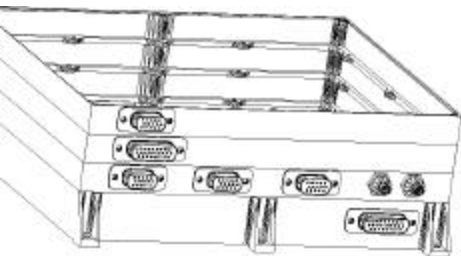

DPU

IMPACT Suite

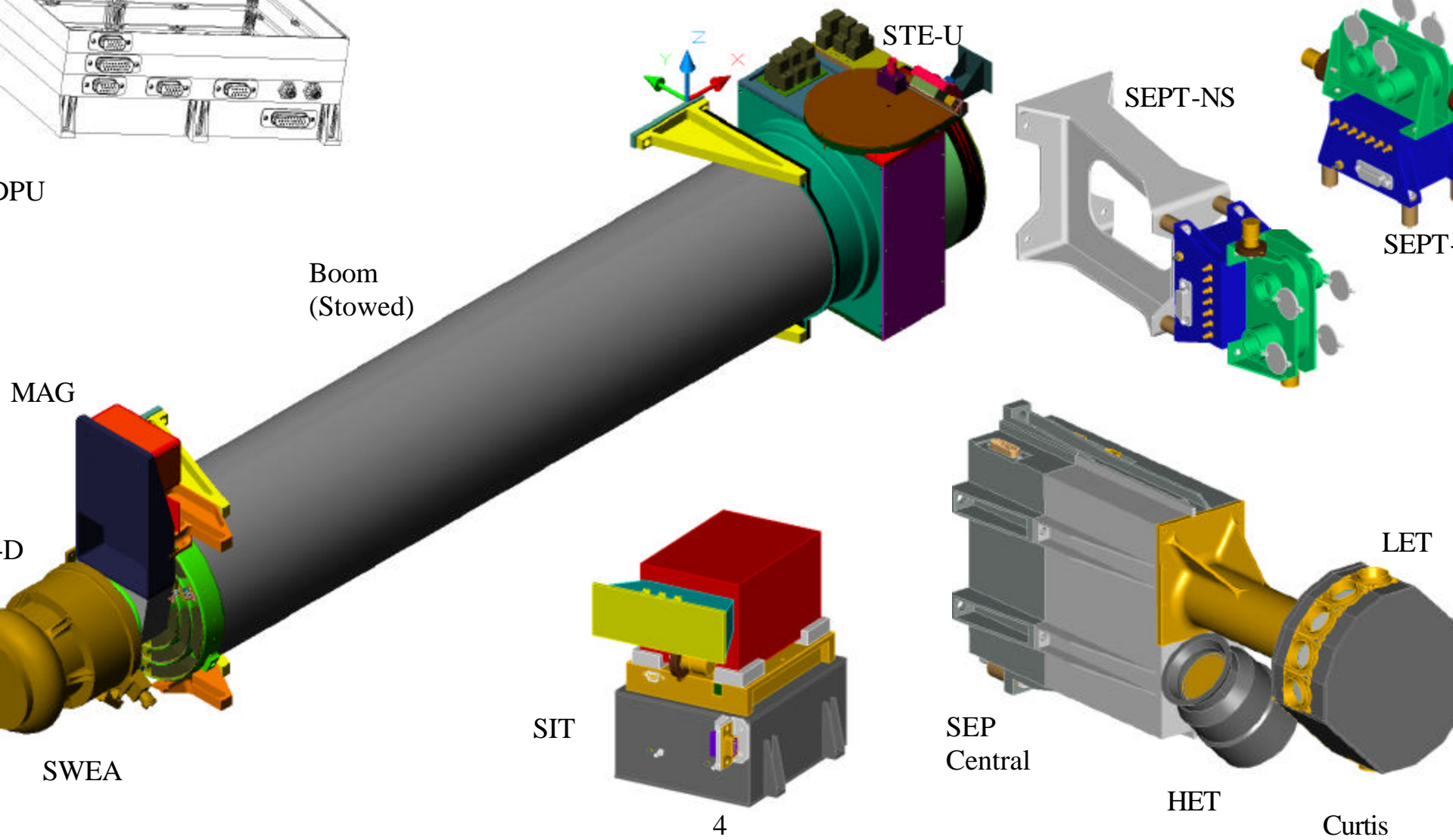

Boom
(Stowed)

STE-U

SEPT-NS

SEPT-

MAG

D

LET

SWEA

SIT

SEP
Central

HET

Curtis

STEREO IMPACT

Observatory Critical Design Review
2003 February 18-21

IMPACT Block Diagram

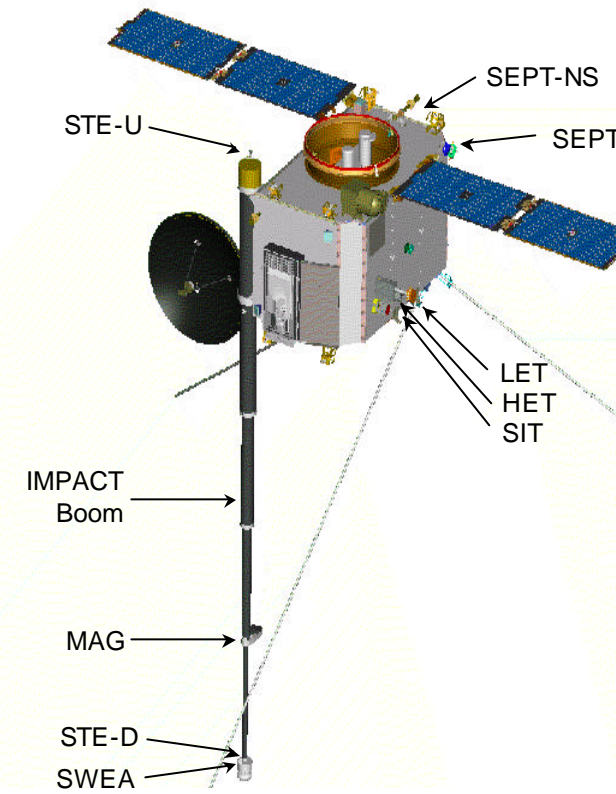
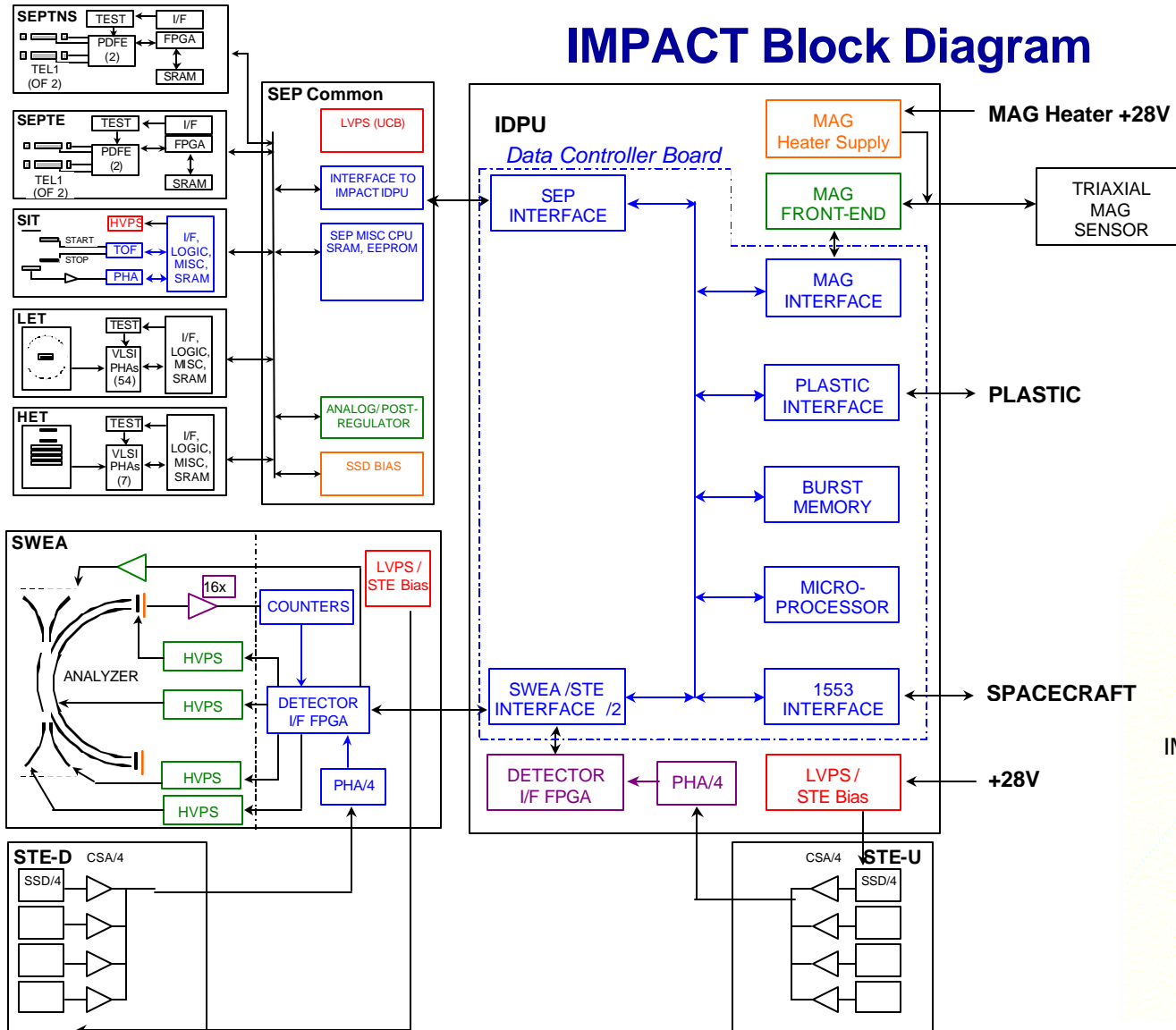

Instrument Development Status

- **Boom**
 - ETU assembled and tested
 - Qual unit in fabrication
- **IDPU**
 - ETU complete and tested
 - Instrument interface tests with ETUs in progress
- **Power Converters**
 - ETU SIT HVPS & IDPU LVPS complete
 - Remaining 3 LVPS ETU in layout
- **SWEA**
 - ETU complete, tested, delivered to UCB
 - Interface tests in progress
 - Selected flight fab has begun
- **STE, SWEA/STE Interface**
 - ETU fabricated, subassemblies in test
- **MAG**
 - Heritage design
 - ETU of STEREO-unique circuits fabricated and tested.

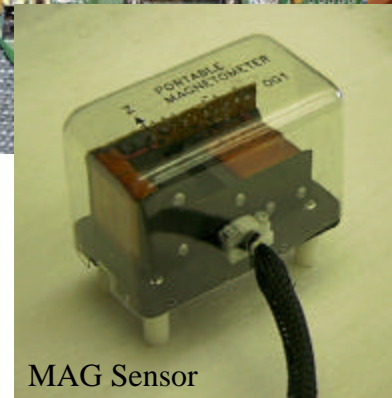
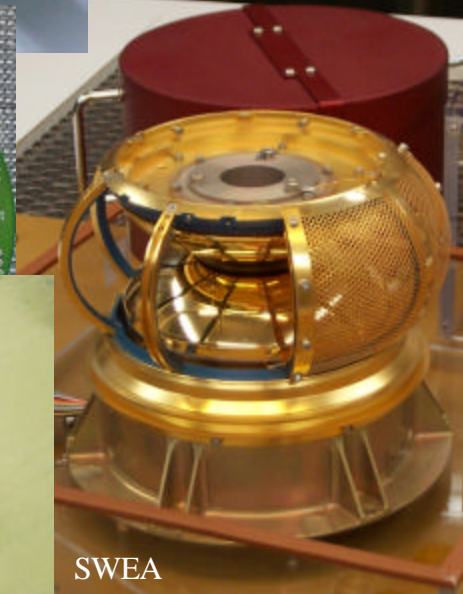
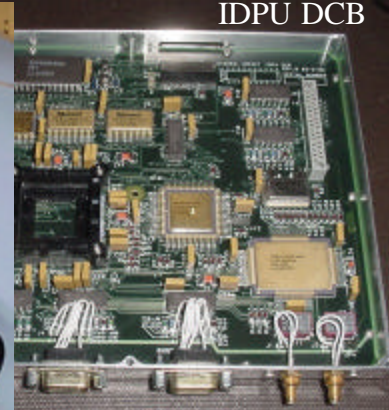
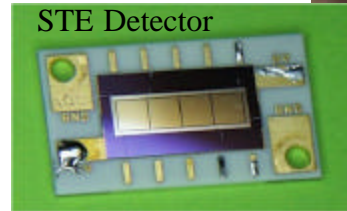

Instrument Development Status (SEP)

- SEPT
 - ETU fabrication in progress, on schedule for SEP ETU integration
- SIT
 - Heritage telescope design; New electronics
 - ETU I&T in progress
- HET, LET
 - ETU in the layout/piece-part drawing stage, on schedule
- SEP Central
 - ETU in the layout/piece-part drawing stage, on schedule

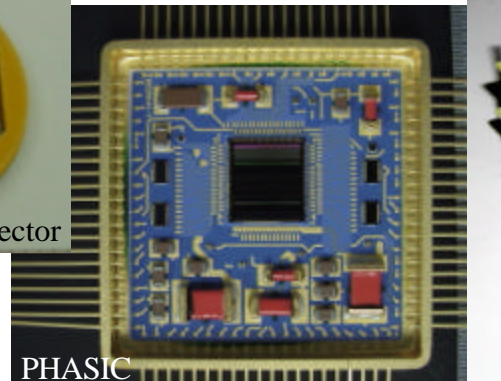
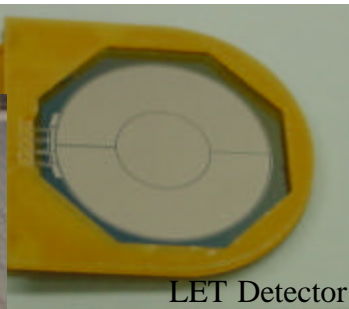
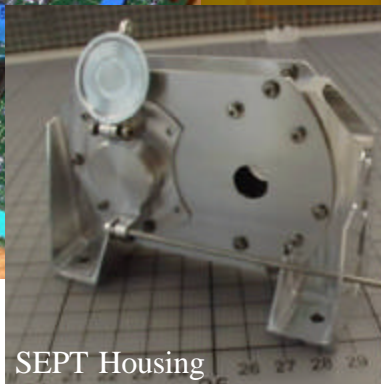
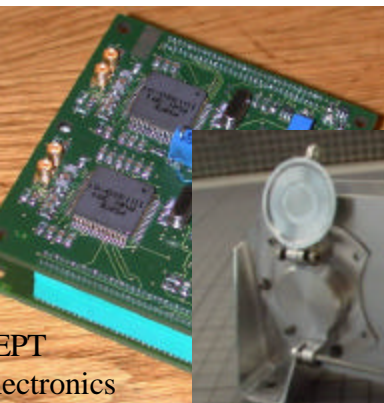
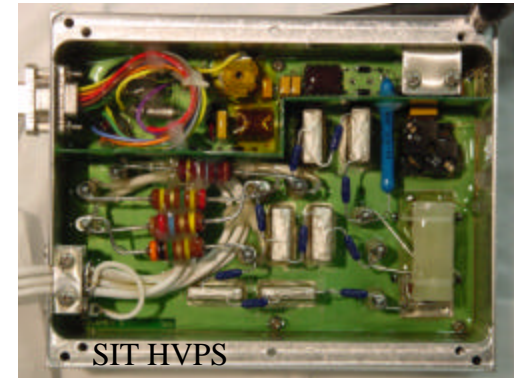

Curtis

Technical Status

- **Overall percentage drawings complete:**
 - **Electrical:**
 - **~98% completed schematics**
 - **~67% layouts complete**
 - **Mechanical:**
 - **Design ~95% complete**
 - **Parts drawings ~84% complete**
 - **SEP mechanical parts drawings lag, but on schedule**
 - **Waiting on final details from electrical layouts**
- **Development plan call for completion of ETU unit testing prior to starting on Flight Hardware**

Approved by: Janet Luhman
Checked by: David Curtis
Prepared by: Robert Palfy

IMPACT SUITE - IDPU & Boom Suite

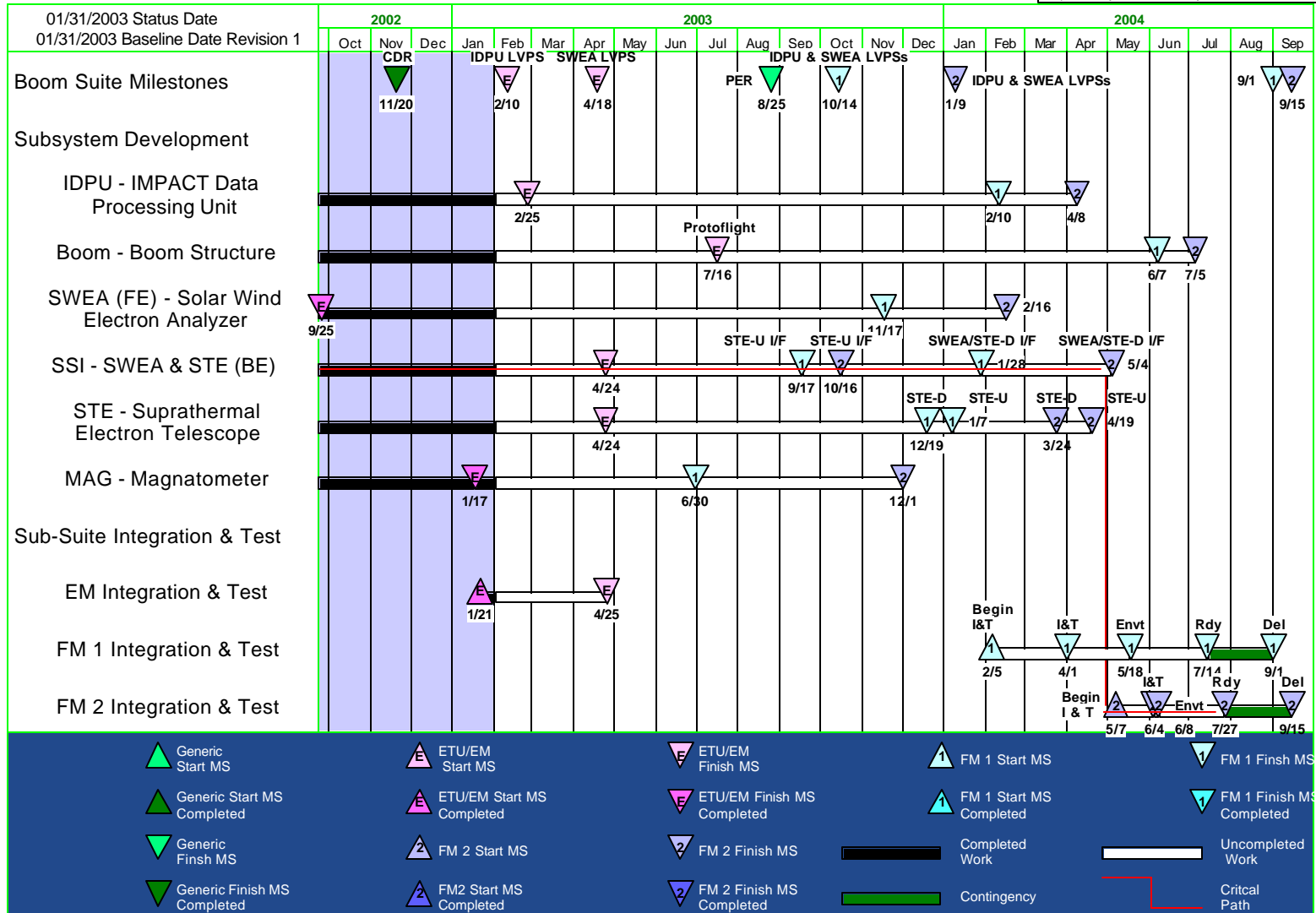

Approved by: Janet Luhman
Checked by: David Curtis
Prepared by: Robert Palfy

IMPACT SUITE - SEP PACKAGE

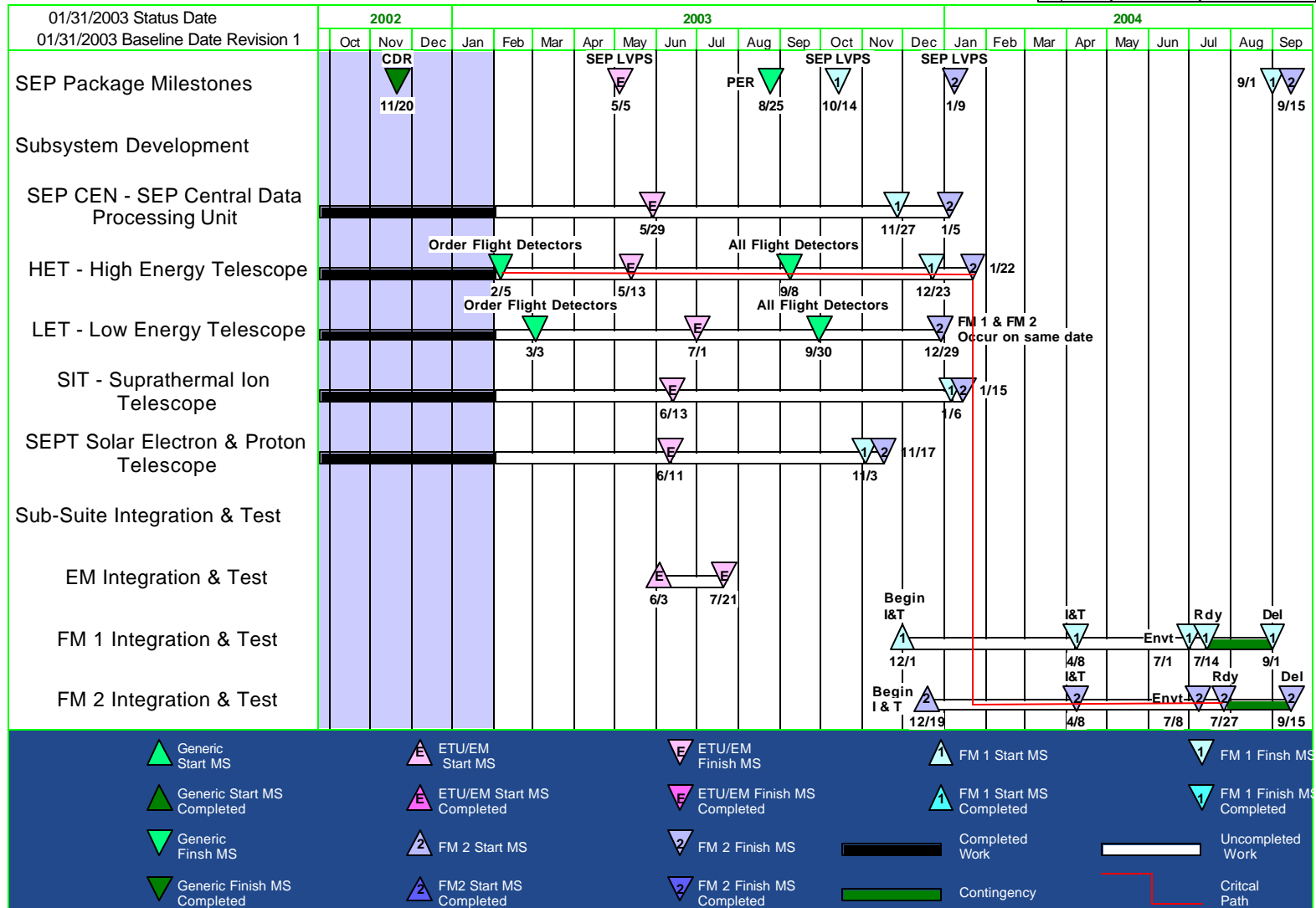

Schedule Summary

- **Since PDR schedule slippage has resulted in contingency to delivery of IMPACT to APL on the baseline schedule dropping from 50 to 7 days.**
 - **Technical problems (LET detectors, parts screening failure)**
 - **Delays in ramping up manpower (Boom and Power Converters)**
- **Schedule drivers have been addressed incrementally as they come up, and have been liened by Project.**
 - **Extra manpower in IDPU Flight Software Development**
 - **Extra manpower in the Boom and LVPS areas**
 - **Parallel LET detector development paths**
 - **SWEA/STE part screening failure recovery**
- **Often these workarounds are not reflected in the original schedule because they involve re-ordering of tasks, allowing tasks to run in parallel, or result in decreasing the duration of future tasks (added manpower)**
- **A re-worked schedule taking these work-arounds into account is presented here**
 - **The new schedule has 35 days of contingency at the end, plus additional slack embedded before key milestones (10 days on SEP critical path, 20 days on Boom Suite critical path)**

Schedule Management

- **Key interface deliveries are coordinated and tracked**
 - External interfaces (APL, PLASTIC)
 - Foreign contributors (CESR, Kiel, ESTEC, MPAe)
 - Internal team deliveries
- **All schedules are incorporated into an overall integrated IMPACT schedule**
- **Schedules are statused monthly**
 - Statusing supported by site-visits by planners
 - Impact of updates are assessed, reviewed between subsystems concerned
 - Effort is then made to bring the date back in line
 - Key milestones identified, monitored, and reported on to STEREO Project
 - Key milestones are those that drive deliveries, critical path or impact cost
- **Coordinated by monthly progress reports, numerous telecons, meetings, and site-visits**

IMPACT CRITICAL MILESTONE SCHEDULE

1/31/03

ITEM	EVENT	2002		2003											
		Nov	Dec	Jan	Feb	Mar	Apr	May	Jun	Jul	Aug	Sep	Oct		
1	IMPACT - Instrument CDR	▼	11/22												
2	MAG - Deliver ETU to UC-B			▼	1/20										
3	IMPACT - Flight ACTEL Lot Buy Received			▼	1/20										
4	LET - L1 Detector Decision Trigger Event			▼	1/31										
5	Place HET Flight Detector Order				▽	2/5									
6	IMPACT - Flight ACTEL Lot DPA Complete				▽	2/7									
7	IDPU - ETU LVPS Available				▽	2/10									
8	IDPU - ETU Complete (Final Testing)					▽	2/25								
9	Place LET Flight Detector Order					▽	3/3								
10	SWEA/STE-D - ETU LVPS Available							▽	4/18						
11	STE - ETU Complete							▽	4/24						
12	SWEA - ETU Complete							▽	5/2						
13	SEP - ETU LVPS Available							▽	5/5						
14	HET EM to CIT							▽	5/8						
15	PLASTIC - ETU LVPS Delivered									▽	6/9				
16	SEPT ETU to CIT									▽	6/11				
17	Completion of Boom Protoflight Unit										▽	7/16			
18	All HET Flight Detectors Received											▽	9/8		
19	All LET Flight Detectors Received												▽	9/30	
20	SEP Package EM I&T Complete													▽	10/2

IMPACT Top 10 Risks

No.	Risk Item	Score	Mitigation	Mitigation Schedule						
				PDR	EM Test	CDR	Sub-system Test	System Test	Env test	Early Orbit Test
UCB_5	IMPACT boom is a new design. Failure could affect Imager pointing requirements as well as boom-mounted instruments.	MEDIUM	Design for reliability. Early prototype testing. Adequate force margins.	MEDIUM	MEDIUM	MEDIUM	MEDIUM	MEDIUM	MEDIUM	LOW
UCB_4	The IDPU is a single point failure mechanism for the IMPACT suite and PLASTIC	MEDIUM	IDPU is a simple, reliable system. Extra attention will be paid to ensuring its reliability, minimizing the risk of fault propagation. Early prototype testing; extensive FM testing	MEDIUM	MEDIUM	MEDIUM	MEDIUM	MEDIUM	MEDIUM	MEDIUM
UCB_23	Non-standard parts qualification failure could impact delivery schedule	MEDIUM	Early parts selection and screening	MEDIUM	MEDIUM	MEDIUM	LOW	LOW	LOW	LOW
UCB_27	Actel timing differences between flight & ETU parts may cause failures late in testing impacting delivery schedule	MEDIUM	Do FM Thermal Vac early to allow time for finding and fixing timing problems; for designs on the critical path, consider installing a flight Actel in the ETU & thermal cycle.	MEDIUM	MEDIUM	MEDIUM	MEDIUM	LOW	LOW	LOW
UCB_11	Stringent EMI requirements may delay schedule if testing fails	MEDIUM	Careful design, ETU power converter testing, early system testing	MEDIUM	MEDIUM	MEDIUM	MEDIUM	LOW	LOW	LOW
UCB_28	Thermal limitations of detectors result in a low bakeout temperature which might require a very long bakeout impacting delivery schedule	MEDIUM	Bakeout subsystems prior to detector integration to reduce time of instrument-level bakeout; early bakeout	MEDIUM	MEDIUM	MEDIUM	MEDIUM	LOW	LOW	LOW
UCB_19	Concern about fragility of ITO surfaces required to meet ESC requirements; failure will impact SWEA science	MEDIUM	Replace ITO with more robust solution where possible; test ITO surfaces during I&T and replace when required	MEDIUM	MEDIUM	MEDIUM	MEDIUM	MEDIUM	MEDIUM	LOW
UCB_10	Complex Interlocking IMPACT schedule increases risk of late delivery to spacecraft	MEDIUM	Detailed fully integrated schedule developed and maintained with Project support. Monthly tracking of status.	MEDIUM	MEDIUM	MEDIUM	MEDIUM	LOW	LOW	LOW
UCB_29	LVPS behind schedule, on critical path; further slipping could delay delivery to spacecraft	MEDIUM	Add manpower to LVPS task to avoid further slippage	MEDIUM	MEDIUM	MEDIUM	LOW	LOW	LOW	LOW
UCB_18	LET Detectors from a new process	LOW	Backup L1 detectors; low risk, meet requirements; Decision point 1/2003	MEDIUM	LOW	LOW	LOW	LOW	LOW	LOW

IMPACT Deliverables by CDR

- **Configuration Management Plan**
- **Performance Assurance Implementation Plan**
- **Software Management Plans**
- **Performance Specification**
- **Environmental Test Plans**
- **Requirements Verification Plans**
- **Data Management/Processing Plan**
- **Preliminary Instrument Users Manuals**
- **Thermal & Structural Analytical Models**
- **FMECA inputs**
- **Parts & Materials Lists**
- **Block & Grounding Diagrams**
- **SWAVES/IMPACT ICD**
- **PDR Presentation**
- **CDR presentation**

Interface Control Documents

- **IMPACT/Spacecraft ICD (APL document 7381-9012, rev A)**
- **IMPACT/SWAVES ICD (IMPACT-SWAVES-ICD_A)**
- **PLASTIC Flight Software Requirements**
 - **PLASTIC_DPU_July_2002**
 - **PLASTIC_Commands**
- **IDPU/Instruments ICD (IMPACTSerialInterface_G)**
- **UCB/CESR SWEA ICD (SWEAICD_F)**
- **Power Converter Requirements (LVPS_Requirements_D)**
- **MAG Interface Card Outlines**
 - **MAG PC BOARD_REV3**
 - **MAG HEATER PC BOARD**
- **MAG Sensor ICD (MAG_Sensor_ICD_A)**
- **Harness wiring and pinouts (IMPACT_Harness_E)**
- **IDPU Software Requirements (IDPUSoftwareRequirements_C)**

Interface Control Documents, Continued

- **HET-SEP_Central ICD (STEREO-CIT-008.A)**
- **LET-SEP_Central ICD (STEREO-CIT-009.A)**
- **SEPT-SEP_Central ICD (STEREO-CIT-010.A)**
- **SIT-SEP_Central ICD (STEREO-CIT-011.A)**
- **LET & SEP Central Software Requirements (STEREO-CIT-002.E)**
- **HET Software Requirements (HETRequirements)**
- **SIT Software Requirements (SITRequirements)**

I&T Plans

- **IMPACT Environmental Test Plan**
- **IMPACT Requirements Verification Plan**
- **IMPACT Verification Matricies**
- **IMPACT Boom Test Plan**
- **IMPACT ETU Development and Test Plan**

IMPACT CDR RFA Status

- **IMPACT team received 32 RFAs**
 - Actions have been assigned to team members
 - 15 Responses submitted
 - Most of the rest should be submitted by the end of February

IMPACT CDR RFA CLOSURE STATUS (CDR DATE: November 20-22, 2002)				
RFA No.	RFA TITLE	ORIGINATOR	STATUS	DATE CLOSED
1	IDPU ETU	Sizemore	Curtis, 2003-1-29	
2	Off-Loading Dave Curtis	Sizemore	Curtis, 2003-1-29	
3	Boom Testing	Sizemore/Battel/ Stewart	Turin	
4	Boom behind Schedule	Sizemore	Turin	
5	ETU Development and Test Plan	Sizemore/Bay	Curtis, 2003-1-29	
6	IDPU failure Free Hours	Taylor	Curtis, 2003-1-29	
7	Boom Risk Assessment	Taylor	Turin	
8	Early Magnetics Test	Gold	Curtis, 2003-1-29	
9	IDPU Boot Code Verification	Gold	Curtis, 2003-1-29	
10	SIT Door Spring	Gold	Tycho/Shuman	
11	SIT Dorr Temperature	Gold	Tycho/Shuman	
12	Cover Over Flywright Brake Mechanism	Stewart	Turin	
13	Contamination Test After Vibration	Stewart	Turin	
14	Adding Third set of Comb	Stewart	Turin	
15	Schedule Update	Jones/Nelson/ Clemmons	Curtis, 2003-1-29	
16	Joint De-lamination	Nelson	Turin	
17	Comb & Kickoff spring System	Nelson	Turin	
18	Chassis Current	Davis	Curtis, 2003-1-29	
19	28V Nosie onto SWEA & SEP	Davis	Curtis, 2003-1-29	
20	IDPU Emissions	Clemmons	Curtis, 2003-1-29	
21	Mass and Power Estimates	Ho	Curtis, 2003-1-29	
22	IDPU Structure Design	Bangs	Turin	
23	SEP Software	Nguyen	Cummings/Davis	
24	IDPU/Spacecraft Thermal ICD	Nguyen	Curtis, 2003-1-29	
25	SEP Thermal Design	Nguyen	Tycho/Hawk	
26	IDPU Thermal Testing	Nguyen	Curtis, 2003-1-29	
27	Boom Heaters	Nguyen	Turin	
28	50kHz Clock	Battel	Curtis, 2003-1-29	
29	Reliability Enhancement	Battel	Curtis	
30	LVPS Topology	Battel	Berg	
31	Foils Qualification	Battel	Mueller-Mellin, Cummings, Tycho	
32	IDPU Parts ELDR Test	Battel	Curtis, 2003-1-31	