

**GEO CORONAL
DETECTOR ASSEMBLY**

QUALIFICATION VIBRATION

Test Procedure

Dwg No 8113-W7 Rev B
Space Sciences Laboratory
13 April, 1998

SIGNATURES

_____ Dr. Stephen Mende,
IMAGE FUV P.I. _____ Date

_____ H. Heetderks,
IMAGE FUV
Project Manager _____ Date

_____ J. Hoberman
GEO Cog E _____ Date

Prepared by:

_____ J. Hoberman _____ Date

1.0 SCOPE

1.1 Introduction

This document describes the test procedure to be used in the qualification vibration test for the GEO Coronal Detector Assemblies. It defines test objectives, test responsibilities, test equipment, environmental conditions and the test sequence for the Sine Sweep, Sine Vibration and Random Vibration tests.

1.2 Test Objectives

The objective of this test is to meet the requirements in EM number S-8089-SYS-003B from SwRI. This plan verifies that the GEO detectors can successfully withstand acceptable levels of environment stress and subsequently function to its specified performance.

1.3 Test Unit

The Image FUV GEO subsystem under test will be referred to as the UUT in this specification, the Unit Under Test.

1.3.1 Identification

The general layout of each of the UUT is shown in Attachment #1. "Test Unit Configuration"

The size of the unit is approximately:

Height = 6 inches
Width = 4 inches
Depth = 11 inches
Mass = .91 kg

1.3.2 Functional configuration of accelerometers and UUT:

The accelerometers are to be applied at strategic locations as described in Attachment #3 "Accelerometer Location".

2.0 Documents

2.1 Applicable Documents

[1]	8110-A4 Rev B	FUV Integration and Test Flow
[2]	S-8089-SYS-003B	Instrument Environments
[3]	8306-W7	Functional Test Procedure for the IMAGE FUV GEO subsystem

3.0 TEST ENVIRONMENT

3.1 Personnel Responsibilities

The following personnel are required for the performance of this test:

Test Director – responsible for the test preparation, test coordination, test hardware, test procedure application, and all decision concerning the UUT and the test documents.

Test Conductor(s) – Operators supplied by vibration test contractor.

3.2 Safety and Precautions

Normal safety precautions for aerospace optics shall be observed. The test unit must be kept packed as long as possible.

3.3 Test Facilities and Equipment

3.3.1 This test will be performed at Viking Laboratories, or other qualified contractor.

3.3.2 The following is a list of equipment and instrumentation required for vibration testing.

No.	Designation and Description	Supplier	Requirements
1	Vibration Exciter	Vib Contractor	N/A
2	Transverse Table 24" x 24"	Vib Contractor	N/A
3	Vibration Control and Data Handling System	Vib Contractor	Calibrated
4	Accelerometers	Vib Contractor	Calibrated
5	Vibration Test Fixture	Vib Contractor	N/A
6	Torque Wrenches	Vib Contractor	Calibrated
7	Tool Box: Isopropyl Alcohol, wipes, Camera	Vib Contractor	N/A
8	Log Book	UCB	N/A
9	Equipment Calibration Table	Vib Contractor	N/A
11	EGSE test set up	UCB	N/A
12	OGSE test set up	UCB	N/A

3.4 TEST SEQUENCE

	Test Sequence Designation	Description
Facility Survey	TS101	Test Readiness Review
	TS102	Visual Inspection
	TS103	Functional Test
Vibration Test in X axis	TS201	X axis Sine Sweep
	TS202	X axis Sine Vibration
	TS203	X axis Random Vibration
Vibration Test in Y axis	TS301	X axis Sine Sweep
	TS302	X axis Sine Vibration
	TS303	X axis Random Vibration
	TS304	X axis Sine Sweep
	TS305	Visual Inspection
Vibration Test in Z axis	TS401	Y axis Sine Sweep
	TS402	Y axis Sine Vibration
	TS403	Y axis Random Vibration
	TS404	Y axis Sine Sweep
	TS405	Visual Inspection
Inspection	TS501	Z axis Sine Sweep
	TS502	Z axis Sine Vibration
	TS503	Z axis Random Vibration
	TS504	Z axis Sine Sweep
	TS505	Visual Inspection
Inspection	TS601	Post vibration visual Inspection
	TS602	Post vibration functional test

3.5 TEST SPECIFICATIONS

3.5.1 Equipment Accuracy

Tolerances of measured parameters are the following:

-Sinusoidal Vibration	10%
-Random Vibration	PSD ± 2 dB; gRMS $\pm 10\%$
-Frequencies	10%
-Time	10%

3.5.2 Vibration Axis

The vibration axes correspond to the GEO Coronal Detector reference axes (Xi, Yi, Zi). See Attachment #2.

3.5.3 Test Levels

The test levels are in accordance with Engineering Memorandum number S-8089-SYS-003B. Vibration test levels will be to the Qualification level.

3.5.3.1 Sine Sweep

Input:	Frequency Range	Acceleration
All Axes	5-2000	.5 G
Sweep rate:	2 oct/min	

3.5.3.2 Sine Vibration

Input:	Frequency Range (Hz)	Displacement Amplitude or Acceleration
<i>Axial axis (Z)</i>	10 to 20 20 to 100	.20 inch DA 4.0 G o-p
<i>Lateral axes (X,Y)</i>	10 to 50 50 to 100	.008 inch DA 1.0 G o-p

Sweep rate: 2 oct/min; 1 sweep

Duration: turn off vibrations soon as acceleration level is reached at the end of the frequency range.

Documentation: acceleration Vs time plots for all accelerometers

3.5.3.3 Random Vibration

Frequency (Hz)	Levels (PSD - G²/Hz) Qual & Protoflight
20	0.026
20-50	+6 db/oct
50-800	0.16
800-2000	-6db/oct
2000	0.026
Overall	14.1 Grms

Duration: three minutes in each axis for Qualification Testing
One minute in each axis for Protoflight Testing

Tolerances: PSD +- 3 db
Overall +- 10%
Duration +- 10%/-0%

Application: All three axes

3.6 FAILURE CRITERIA AND FAILURE REPORTING

All failures shall be recorded, along with all test parameters, at the time of discovery, in the Test Unit Logbook.

3.6.1 Failure

A unit failure shall be reported for any of the following reasons:

- a) Physical damage found during the test or during the post-vibration inspection of the unit.
- b) Any significant shift in the resonant frequencies of the instrument structure coupled with significant decrease (softening) in the structural stiffness.
- c) UUT no longer meets its specified functional performance (8306-W7).

3.6.2 Test Failure

Other types of failures do not constitute a UUT failure. The unit may require retest as a result of the Material Review Board (MRB) decisions, for any of the following, but not limited to:

- a) Failure of test instrumentation;
- b) Deviation of the vibration facility from specified tolerances;
- c) Deviations from the vibration test procedure.

5.0 TEST SET-UP

5.1 Test Configuration

The UTT will be mounted to the vibration facility tables for excitation in the X, Y and Z axis. See figures in Attachment #2 "Test Set-Up". Vibration is performed on one axis at a time.

5.2 Test Fixtures

The test fixture provides the interface between the UUT and the vibration table. See figures in Attachment #2 "Test Set-Up".

5.3 Accelerometers Installation

The location of all the accelerometers, in relation to the UUT, is shown in Figures 3.1 & 3.2, of Attachment #3. These figures show the location of each accelerometer within the test set up, and should be referred to during installation.

6.0 **TEST PROCEDURE** (Step by Step)

Step No.	<u>Procedures:</u> Test Set-Up and Check Out	Date	Test Conductor
101	Test Readiness review		
101.1	Unpack test unit.		
101.2	Fit check test fixtures		
102.1	Visually inspect UUT. Verify that the unit is in accordance with the definition in section 1.3 "Test Unit" and is not physically altered during transportation.		
201.1	Mount UUT in test fixture for vibration test.		
201.2	Perform TS201 (Sine Sweep).Ref.Sec.3.5.3.1		
201.3	Record data and review for conformance. Record run designation _____.		
201.4	Record first global eigenfrequency:_____.		
201.5	Perform TS202 (Sine Vibration) Ref. Sec. 3.5.3.2.		
201.6	Record data and review for conformance. Record run designation _____.		
201.7	Perform TS203 (Random Vibration) Ref. Sec 3.5.3.3.		
201.8	Record data and review for conformance. Record run designation _____.		

6.0 **TEST PROCEDURE** cont'd (Step by Step)

Step No.	Procedure: Test in X axis TS301-305	Date	Test Conductor
301	X axis Sine Sweep		
301.1	Wipe mounting with alcohol		
301.2	Mount UUT in test fixture, for excitation in the X axis. Ref. Fig.2.3 Attachment #2.		
301.3	Mount monitor and control accelerometers to UUT. Ref. Fig.3.1 & 3.2 of Attachment #3		
301.4	Take photos of set-up and measurement locations.		
301.5	Perform Sine Sweep. Ref. Sec. 3.5.3.1		
301.6	Record data and review for conformance. Record run designation _____.		
301.7	Record first global eigenfrequency: _____.		
302	Perform Sine Vibration. Ref. Sec. 3.5.3.2.		
302.1	Record data and review for conformance. Record run designation _____.		
303	Perform Random vibration. Ref. Sec.3.5.3.3		
303.1	Record data and review for conformance. Record run designation _____.		
304	Perform Sine Sweep. Ref. Sec. 3.5.3.1		

6.0 **TEST PROCEDURE** cont'd (Step by Step)

Step No.	Procedure: Test in X axis	Date	Test Conductor
304.1	Record data and review for conformance. Record run designation _____.		
304.2	Record first global eigenfrequency: _____		
305	Perform visual Inspection. Refer to Table 2 of Attachment #4.		
401	Mount test fixture and test unit on transverse table, for excitation in Y axis; See Fig 2.2 of Attachment #2.		
401.1	Mount monitor accelerometers to test unit Ref. Fig. 3.1 & 3.2 of Attachment #3.		
401.2	Take photos of test set-up and measurement locations.		
401.3	Perform TS202 (Sine Sweep).Ref. Sec.3.5.3.1		
401.4	Record data and review for conformance. Record run designation _____.		
401.5	Record first global eigenfrequency: _____.		
402	Perform TS402 (Sine Vibration) Ref. Sec. 3.5.3.2.		
402.1	Record data and review for conformance. Record run designation _____.		
402.2	Perform TS203 (Random Vibration) Ref. Sec. 3.5.3.3.		
402.3	Record data and review for conformance. Record run designation _____.		

6.0 **TEST PROCEDURE** cont'd (Step by Step)

Step No.	Procedure: Test in Y axis TS401-405	Date	Test Conductor
404	Y axis Sine Sweep		
404.1	Record data and review for conformance. Record run designation _____.		
404.2	Record first global eigenfrequency: _____.		
404.3	Perform visual Inspection. Refer to Table 2 of Attachment #4.		

6.0 **TEST PROCEDURE** cont'd (Step by Step)

Step No.	<u>Procedures:</u> Test in Z axis	Date	Test Conductor
501	Mount test fixture and test unit on vertical vibration table, for excitation in Z axis; See Fig 2.1 of Attachment #2.		
501.1	Mount monitor accelerometers to test item. Ref. Fig. 3.1 & 3.2 of Attachment #3.		
501.2	Take photos of set-up and measurement locations.		
501.3	Perform TS202 (Sine Sweep).Ref. Sec.3.5.3.1		
501.4	Record data and review for conformance. Record run designation _____.		
501.5	Record first global eigenfrequency:_____.		
502	Perform TS402 (Sine Vibration) Ref. Sec. 3.5.3.2.		
502.1	Record data and review for conformance. Record run designation _____.		
502.2	Perform TS203 (Random Vibration) Ref. Sec 3.5.3.3.		
502.3	Test Conductor to collect test data and review test input for conformance. Record run designation_____		

6.0 **TEST PROCEDURE** cont'd (step by step)

Step No.	Procedure: Test in Z axis TS501-505	Date	Test Conductor
504	Z axis Sine Sweep		
504.1	Record data and review for conformance. Record run designation _____.		
504.2	Record first global eigenfrequency: _____.		
504.3	Perform visual Inspection. Refer to Table 2 of Attachment #4.		

ATTACHMENT # 1

TEST UNIT QUALIFICATION CONFIGURATION

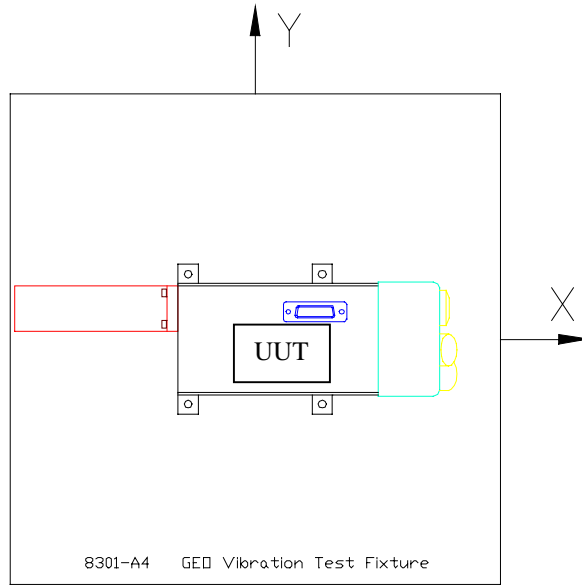

Figure 1-1 -- General Layout

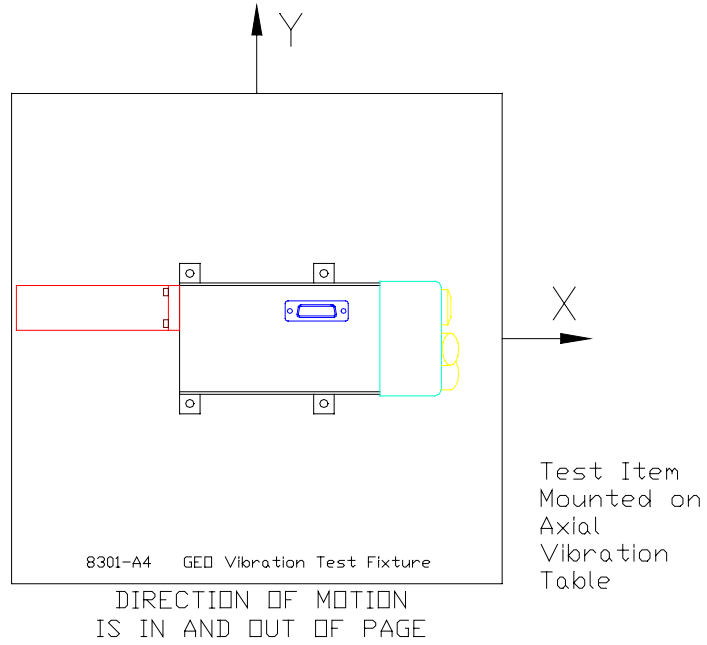

Figure 2-1 -- Set-up for Z axis Vibration

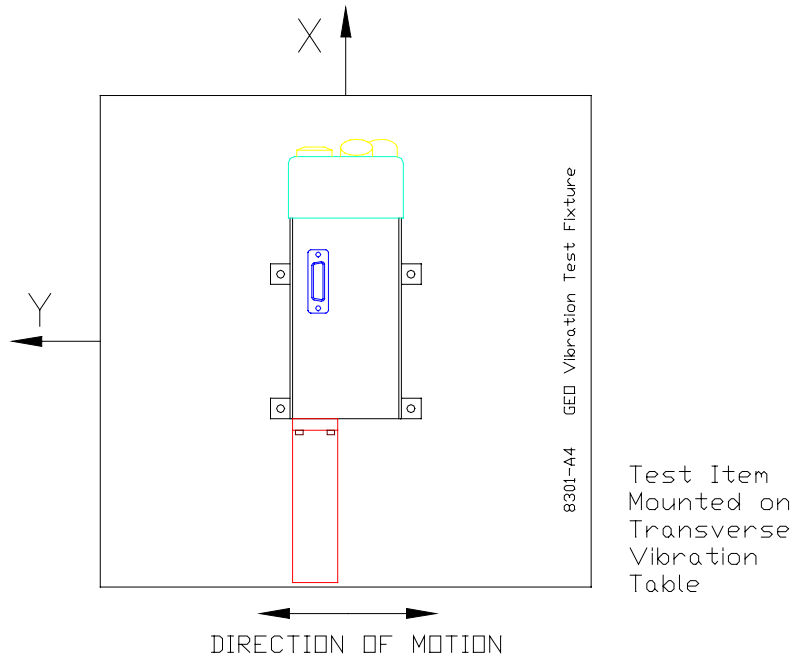

Figure 2-2 --Set-up for Y axis Vibration

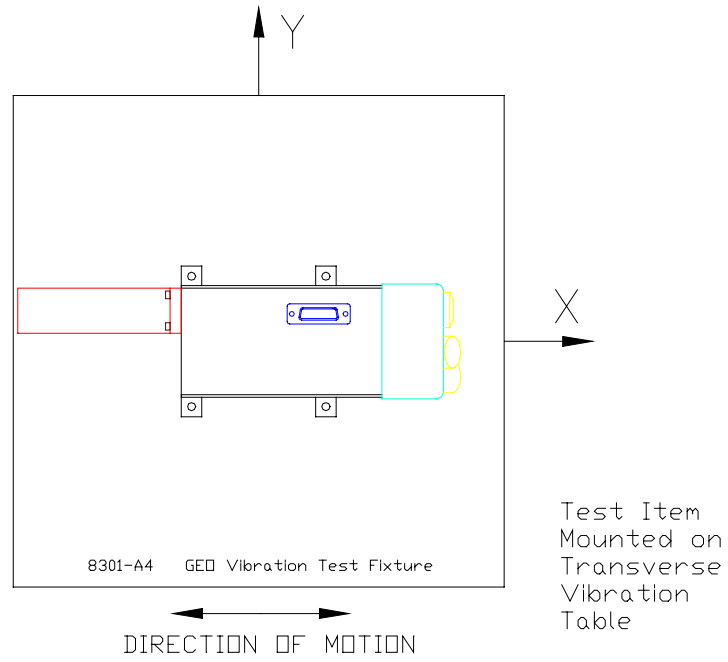
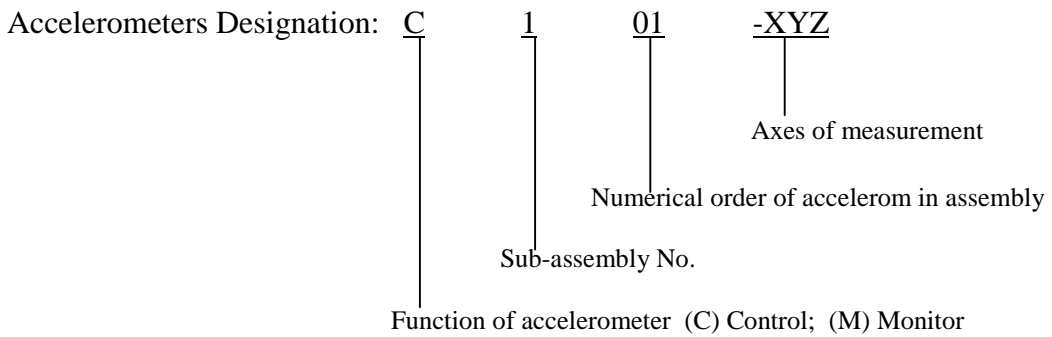

Figure 2-3 -- Set-up for X axis Vibration

Table 1: Accelerometer Designation and Location

Designation	Serial No.	Location Description
		1. Test Fixture
		2. Top Rear of Mainbox
		3. Top Front of Mainbox
		4. Rear of HVPS
		5. As directed by TC



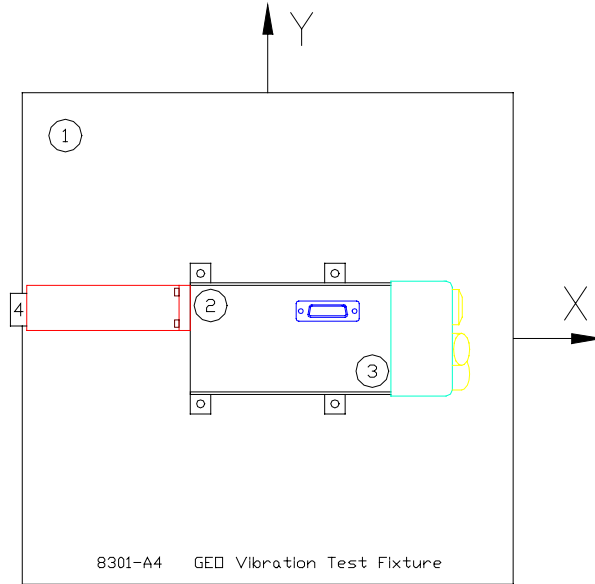

Figure 3-1 -- Accelerometer Locations, Plan View

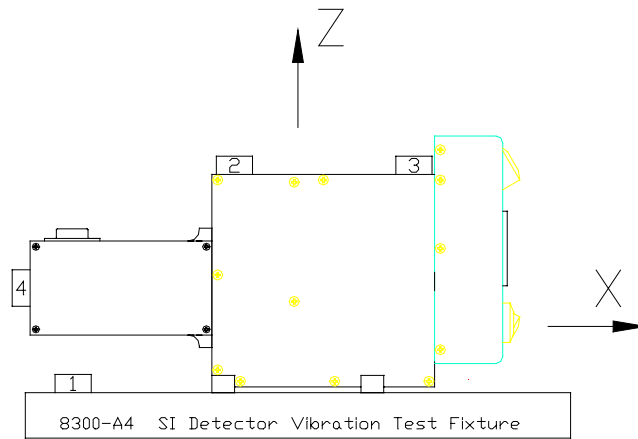

Figure 3-2 -- Accelerometer Locations, Elevation View

Table 2: Post Test Visual Inspection Record

INSPECTION	SIGNATURE	COMMENTS
: 1. Test Unit Visual Inspection 2. Test unit Functional Test 3. 4.		

Test Director / Date